

Oase:

LIVING WATER

MULTI-POND SET CONSTRUCTION MANUAL

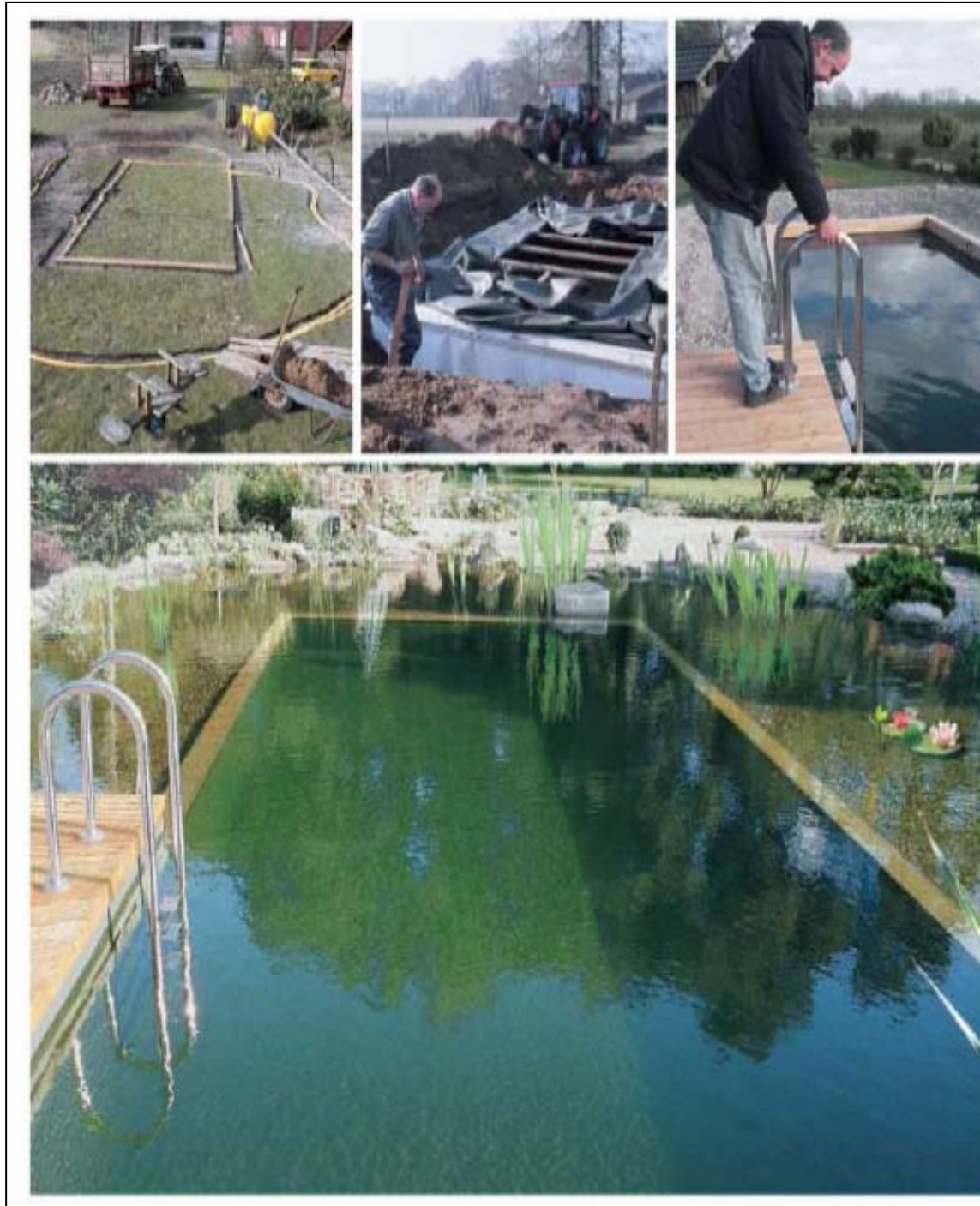

Table of Contents

LOCATION	5
SELECTION CRITERIA	5
Sunlight	5
Falling leaves	5
Wind direction.....	6
Mark the location	6
What do you have to consider when building your pond on a slope?	6
Where can I dispose of the dug material?	6
PERMITS	7
Which measures require a permit?	7
Water protection area.....	7
Nature protection / forest areas.....	7
The boundaries.....	7
Operator's responsibilities.....	7
PREPARATORY MEASURES	7
Distances to adjacent constructions	7
Supply lines on the property	7
Groundwater situation	8
Make sure to clear your entire construction before starting to dig. You should, of course, also pick up or remove any existing pathways or paving.....	8
Build a path.....	8
Specify the reference heights.....	9
Determine the digging depth.....	9
Which building materials in what quantities will I need?	10
MAN AND MACHINE	11
Building machinery	11
Manpower.....	11
What kind of power do you need?.....	11
How many power outlets do you need?	11
Where should you install the outlets?	12
THE FILLER WATER.....	12
Water values.....	12
pH value	12
GH value (total hardness)	12
KH value (carbonate hardness)	13
NO ₃ -Nitrate	13
PO ₄ -Phosphate	14
LET'S GET TO WORK.....	14
Prepare your dig.....	14

Peg out the Multi-Pond.....	15
Excavate the Multi-Pond.....	15
Strip footing.....	15
THE DEEP ZONE.....	16
Setting up the wall elements.....	16
Aids for crossbracing.....	21
Bracing aids.....	21
FILLING AND SEALING THE SOIL, PART 1	23
WORKING ON THE POND LINER, PART 1	23
Spread the protective fleece below the pond liner.....	23
FILLING AND SEALING THE SOIL, PART 2	25
CONNECTION POND EDGE / WALL.....	26
Shaping the future shallow areas of your pond.....	26
Building the capillary barrier.....	26
For draining sub-surfaces.....	27
For non-draining subsurfaces.....	28
Spreading the protective fleece further.....	28
WORKING ON THE POND LINER, PART 2.....	28
Spreading the pond liner all the way.....	28
Even more protective fleece.....	28
BEFORE POURING THE GRAVEL.....	28
Installing the wooden border of the deep zone.....	28
The pipeline kit.....	30
Positioning the filter system.....	30
Installing the filter.....	30
Laying and connecting the pipes.....	31
GRAVEL INTEGRATION	32
Gravel heaps with a function.....	32
Three layers of gravel.....	32
THE WOODEN DECK	32
Delivery condition.....	32
Assembly.....	32
PLANTING RECOMMENDATION.....	33
PLANTING	34
Filling the deep zone all the way to the shallow zone.....	34
What do you have to keep in mind during planting?.....	35

ALMOST DONE..... 35
Install the entrance ladder 35
Shaping the peripheral area..... 36
Initial operation of your pond system..... 36
Winter operation..... 37

MAINTAINING YOUR SYSTEM 37
The basics 37
What tools do you need to take care of your pond?..... 37
What will you have to do on a regular basis and how often?..... 38

THE FILTER SYSTEM 38
Cleaning by biological filters..... 38
The development of the filter biology..... 38

Information

You have made your decision: you want to create your personal Multi-Pond paradise right in your own backyard.

We would like you to make this dream become a reality without any further ado so that you can enjoy your new Multi-Pond as soon as possible. This is why these instructions will explain each individual step of our construction project.

The location

Choosing the right location can support your Multi-Pond in cleaning itself on a biological basis. This is why, in addition to design considerations; you should also take the following criteria into account.

Selection criteria

Sunlight

Of course, everyone likes their water well-temperated and pleasantly heated when they take a swim.

You will find that the shallow areas of your Multi-Pond provide the most comfortable temperatures. They function as bio collectors and contribute to the quick heating of the bathing water if the pond is located in an area with full sun exposure.

That said, sunlight is also the driving force behind important biological and physical processes taking place in the water. As a consequence, intense sunlight increases the risk of algae formation. Therefore, you might want to consider to partially shading your pond.

If necessary, trees or similar plants purposely planted by the shallow areas of your pond may provide sufficient shading. Suitable water plants include water lilies which can protect the water surface against direct sunlight thanks to its large floating leaves.

Falling leaves

A Multi-Pond is exposed to various sources of soiling.

In addition to people enjoying the pond, falling leaves and blooms cause an increase in nutrients in the water. Therefore, make sure to consider this factor when selecting a location for your pond.

Careful planning may considerably reduce the need to constantly take care of your pond by scooping the water and emptying the skimmer basket. Thus, you will want to select the right location to minimize nutrient enrichment.

Keep a sufficient distance between your pond and any existing trees.

Trees planted in the immediate vicinity of your Multi-Pond may increase the care requirements of your pond.

Wind direction

Set up the filtering system of your future Multi-Pond such that the direction of the wind will support the skimming performance of your filter.

Mark the location

Once you have found your location, mark the area your pond will probably cover. To do so, use sand, pieces of wood, a garden hose or similar aids.

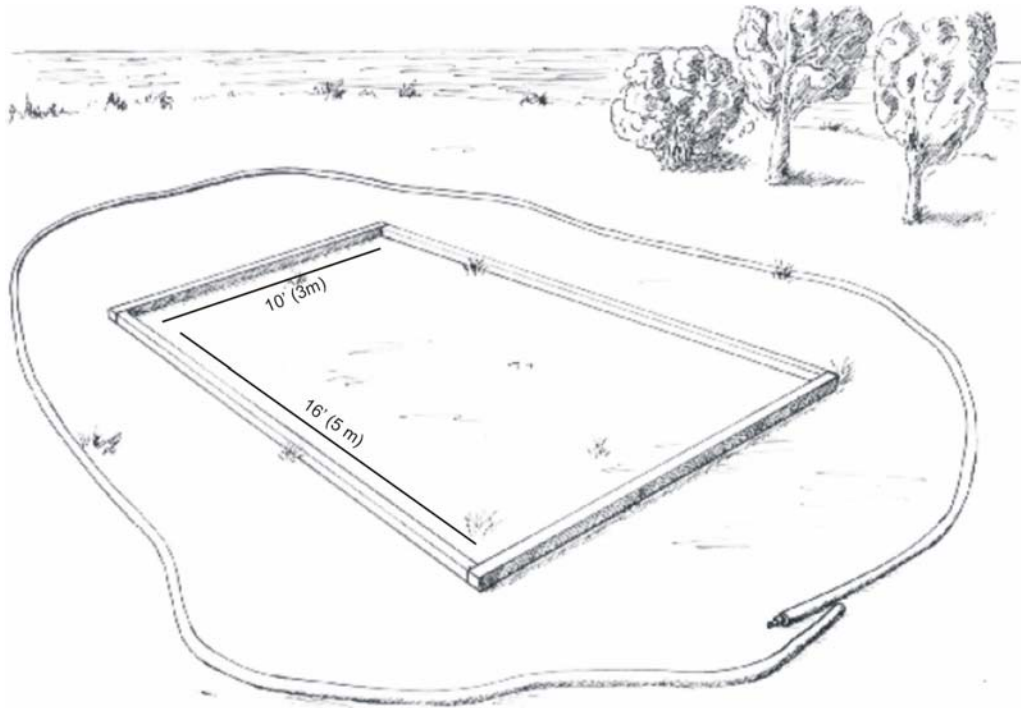

Fig.: Marking the location of your pond

Next, find and mark the relevant spots of your Multi-Pond (dig marks for the deep zone, the regeneration zone, the position of the filter) using suitable sticks or rope pins.

What do you have to consider when building your pond on a slope?

Ideally, any construction like your Multi-Pond should be built into the naturally grown soil. Artificially filled banks or newly created soil moulds may require technical constructions (e.g. support walls) for increased safety and stability.

The same holds true for a construction properly built on a slope. If you plan on building your pond on a slope, consult a professional structural engineer or construction expert.

Where can I dispose of the dug material?

The construction of a Multi-Pond involves a considerable amount of earthwork. Make sure that the soil you dig has a 50% higher volume when in loose condition.

You can either dispose of the dirt removed when excavating your pond or store it to later make use of it when shaping your garden landscape.

Permits

Which measures require a permit?

You will generally be required to observe all locally applicable regulations when building ponds.

This is why you should always contact your local authorities before starting construction on your Multi-pond.

Water protection area

Since your Multi-Pond will be sealed by a pond liner and have no contact with the ground water, you will not have any restrictions from the government agency. That said, you should still contact their local office.

Nature protection / forest areas

The construction of you Multi-Pond may not exceed the construction area for which you have a permit. Should the construction exceed this area, you will have to obtain an exemption from your local community.

The boundaries

Enquire about the boundaries to be observed at your local building authorities. Make sure not to rely on any oral agreements made with your neighbour. Experience shows that a construction project often results in subsequent differences of opinion.

Operator's responsibilities

You, as the operator of a Multi-Pond are responsible for the safety of this installation. This means that you will have to ensure that no person will use the Multi-Pond unauthorized or by accident and sustain any damage while doing so. Secure the area such that no person will be able to access your Multi-Pond unhindered, e.g. by surrounding it with a garden fence and a lockable gate.

Preparatory measures

Distances to adjacent constructions

To prevent existing constructions from becoming structurally unsafe, you should consult an expert before starting to dig your Multi-Pond. This is particularly important if you plan on building your pond in the immediate vicinity of another building. How is the existing building anchored to the ground? Will the subsurface hole the building or is there a chance it will start to shift?

Supply lines on the property

Before stating construction, check if there are any supply lines for power, water, telephone, etc. under the construction site, which may become damaged. Pay particular attention to any gas lines. Contact your local utility company and ask about the minimum distances your are to observe.

Groundwater situation

The presence of groundwater may lead to a collapse of your excavation pit in case water manages to leak in. Water seepage will, of course, render any orderly production process almost impossible.

The quickest way to find if there might be any problems with groundwater is to perform a trial dig at the maximum required depth.

Groundwater levels will usually be lowest in late summer or early fall. We therefore recommend selecting this favourable period in general for your construction activities.

Important note:

The water pressure of a filled Multi-Pond creates a counter pressure that will structurally balance out any higher groundwater levels. This means that your construction will be secured against any groundwater seepage when it is filled. However, high groundwater levels will not allow you to empty your Multi-Pond after it's completed without taking additional measures. As a result, you might have to lower the groundwater level before emptying your pond.

Clean up the construction site

Make sure to clear your entire construction before starting to dig. You should, of course, also pick up or remove any existing pathways or paving.

Build a path

Think about the tools you will need at your construction site. Will you be using a shovel and a pickaxe, will a mini excavator be sufficient or will you require a fullsize excavator? Will you transport your construction materials in a wheel loader or similar vehicles?

Check if the path this machinery will require is large enough.

Measure your pond

You should start by marking the Multi-Pond site before determining the incline of the terrain.

Important information in this regard:

Write down all of your measurements to have them readily available when you need them during construction!

Now, lay out your Multi-Pond in your backyard according to your ground plan. Start by picking an unalterable point of reference (e.g. a corner of your house). To transfer the dimensions of your Multi-Pond, mark a baseline through the area to be excavated. You should lay down this marking using a tape measure of appropriate length. The marking should run as closely as possible to or through the area of the Multi-Pond site to ensure that the rectangular distances to the marked points are as short as possible.

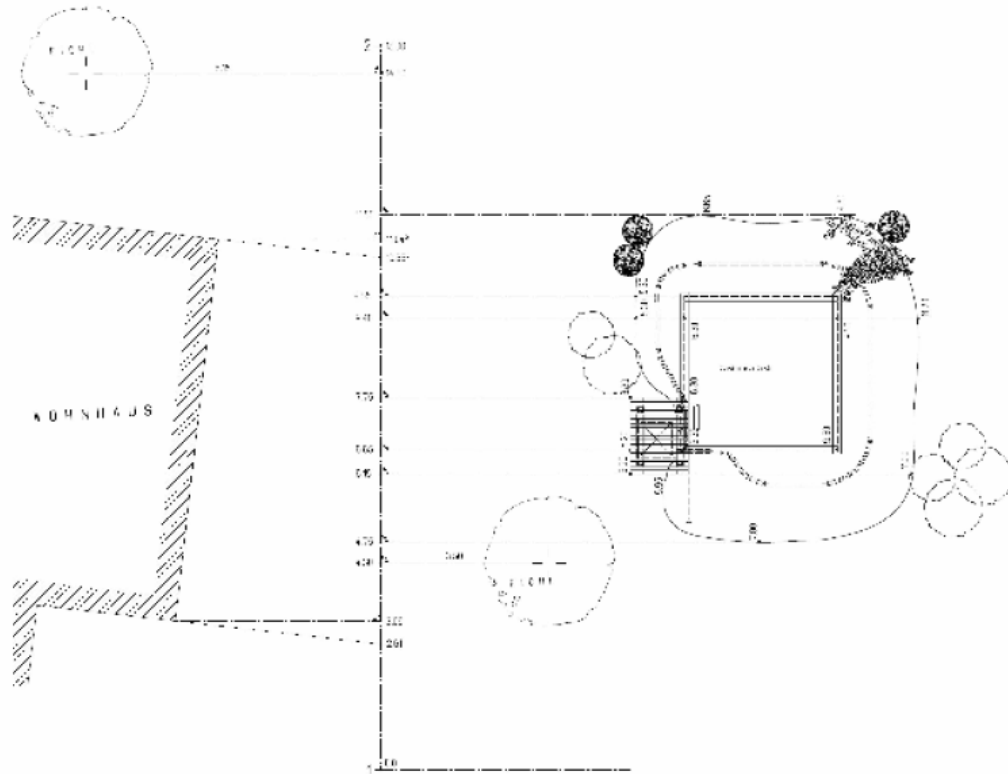

Fig.: example of a baseline measurement

Starting from this baseline, transfer all desired spots to your backyard at a right angle. When you are finished marking (with pieces of wood or similar objects) and connecting these spots, you will be able to see what your future Multi-Pond will look like.

Thanks to its low requirements of technical equipment, this method is well suited to measure the dimensions of your Multi-Pond.

Using a Lazer Level, you can find this base line as well.

Specify the reference heights

Once again, find a fixed point of reference in your backyard and reference it to mean sea level (MSL).

This height is now your fixed reference point for determining and checking all heights for your pond.

The quickest way to determine all heights for your pond is to use a laser level. Today, you will be able to borrow these devices from almost any construction machinery rental company.

You may, of course, also determine a horizontal line of reference in a different manner. Water levels or hose scales suit the purpose just as well.

Determine the digging depth

Set your initial point zero. To dig your Multi-Pond, start from this point zero and dig with opposite signs, i.e. all downward dimensions are labeled with a minus.

For more details, see the following dig plan.

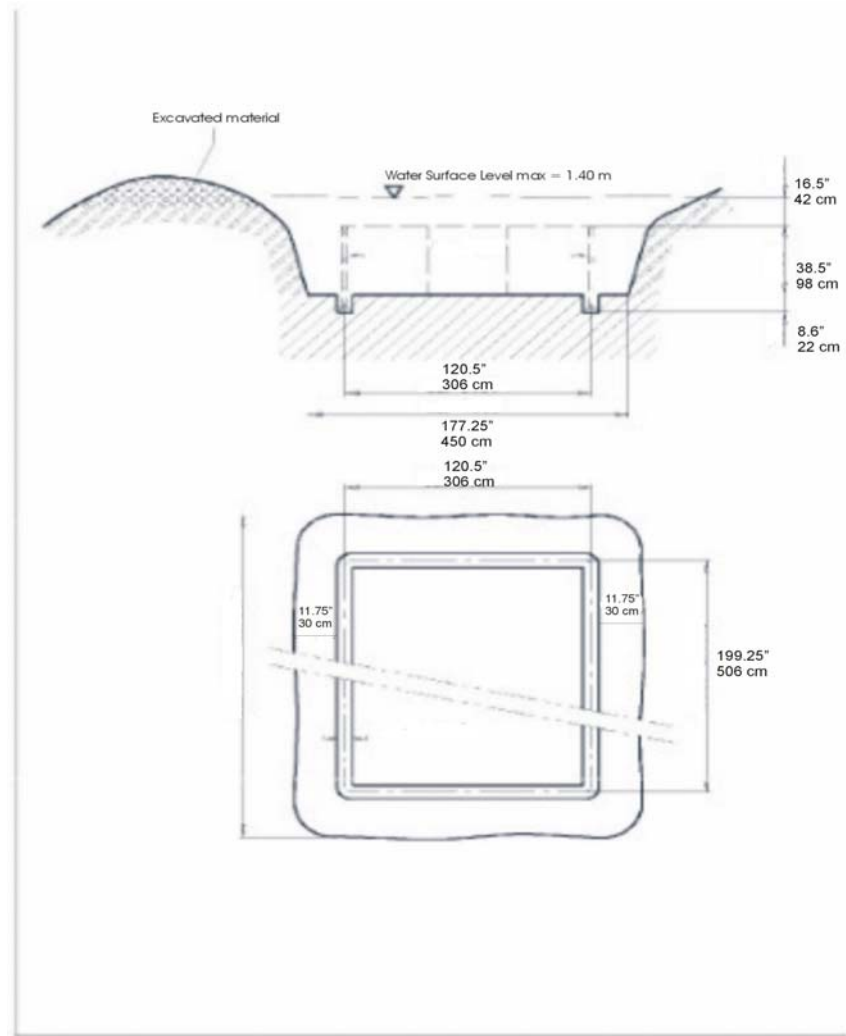

Fig.: Dig plan

Construction materials

Which building materials in what quantities will I need?

The following list contains all building materials and the quantities you will have to purchase.

Please make sure to always obtain several estimates. This will allow you to negotiate and achieve the best price/performance ratio at the building material store of your choice.

Material:

Unit	Multi-Pond Set 10 x 16
------	-------------------------------

Filler sand (depending on existing ground)

[yd ³]	Approx. 4.6
--------------------	-------------

Filtering gravel

Gravel 1/4" (e.g. washed Pea gravel)

[ton]	9
-------	---

Gravel 1/2" (e.g. washed Pea gravel)

[ton] 13

Water plants

[units] 115

Man and machine

Building machinery

We recommend using the following building machinery to make the construction of your Multi-Pond as effective as possible:

- Mini excavator
- Excavator
- Wheel loader
- Laser Level
- Wheel Barrows
- Cordless Power Drill with 10mm socket for installing screws
- Wrenches – 10 mm
- Adjustable wrench
- Phillips Screwdriver
- Measuring Tape
- Yardstick
- Mason's rope
- Rope pins
- Shovels
- Rakes

Manpower

Some of the work on your Multi-Pond set is done most effectively by a team. Please remember to include in your planning the work crew you will need as well as their specific purpose. Most importantly, select the people you want to work on the liner bag. Due to its relatively heavy dead weight (up to 140 kg), the ready-made pond liner requires between 6 and 8 pairs of strong hands to move it around.

Power supply

What kind of power do you need?

The 12 V pump of the filtering system requires electrical power.

All power equipment needs to be plugged into GFI (Ground Fault Interrupted) outlets. Outlet can be no closer than 10 feet to the pond.

How many power outlets do you need?

At first, you will only need one outdoor power outlet for connecting the filter pump. However, we recommend planning to use 2-3 outdoor power outlets. This will prevent you from

running out of connection possibilities if you plan on upgrading your Multi-Pond technology or want to connect other consumers such as lighting or a floor vacuum.

Please note that you may only operate 12 V devices in your Multi-Pond!

Where should you install the outlets?

The power outlets must be installed by a trained electrician, who needs to make sure that they cannot be flooded or exposed to rain and that they have a distance of 10 feet to the water edge of the Multi-Pond.

The filler water

Tap water, well water, and groundwater have properties that are strikingly different from one another. We, therefore, recommend that you have the water you want to use to fill your Multi-Pond analysed. Such an analysis will reveal the quality of your water and its usability for your Multi-Pond. You should, therefore, have this analysis conducted in good time to be able to react in case of considerable deviations from the ideal values.

The most important values are:

- pH value
- GH – total hardness
- KH – carbonate hardness
- NO₃ – nitrate content
- PO₄ – phosphate content

As an owner of a Multi-Pond you should keep an eye on these water values from the very beginning and check them regularly. They are indicators and regulators for all biological processes taking place in your pond system.

Water values

pH value

The pH value is a measure of the strength of an acid or a base. It is measured on a scale of 0-14. Pure water is described as neutral with a pH of 7, while tap water generally has a pH between 6.5 and 8.5. To maintain diverse life in your pond it is essential that your water's value remain stable. Great deviations in pH values are hostile to your system.

Alkaline solutions have a pH value greater than 7. The higher the pH values above 7, the more alkaline the solution. The lower the pH value falls below 7, the more acetous your water becomes.

The optimum for diverse life in the garden pond is pH values between pH 6 and pH 8.5.

The pH value is a logarithmic unit. What this means is that, for example, a change in pH value from 7 to 8 will alter the ratio between acids and bases tenfold. An increase in pH value from 7 to 9 means a change in the acid-base ratio by factor 100.

GH value (total hardness)

The total hardness (GH) is defined as the sum of alkaline earth (saline) ions dissolved in the water. The main components in this regard are calcium and magnesium ions. Calcium is a basic component of all forms of lime. Calcium, for instance, is an important component of snail and sea shells. Plants, too, require small amounts of calcium. Magnesium is a

component the inhabitants of your pond need as a trace element. Magnesium is crucial to plants.

Total hardness is measured in "°DH"(degrees of hardness).

Categorization:

0 to 4	° DH	very soft
4 to 8	° DH	soft
8 to 12	° DH	medium hard
12 to 18	° DH	rather hard
18 to 30	° DH	hard
> 30	° DH	very hard

The total hardness of your filler water depends on its origin. Tap water, well water, and groundwater may have considerable different degrees of hardness.

Ideally, your Multi-Pond water should have GH values ranging from "soft" to "rather hard" (between 4 and 18° dH).

If your water hardness is outside of this range, you may thin your water and, thereby, lower hardness by adding rain water.

KH value (carbonate hardness)

Carbonate hardness is part of the total hardness of your water. It is defined as the portion of calcium and magnesium ions present in the water in the form of carbonate compounds.

The carbonates in your Multi-Pond bind any excess carbonic acid and prevent your pond from becoming too acidic. As this process is a balance reaction, a lack in carbonic acid may lead to a release of carbonic acid. This will buffer and stabilize the pH value.

A stable pH value is vital to maintain diverse life in your Multi-Pond.

Just as the total hardness, the carbonate hardness of your filler water depends on its origin. Tap water, well water, and groundwater may have considerably different degrees of carbonate hardness. Ideally, your Multi-Pond water should have KH values between 3° and 10° dH.

If your water hardness is outside of this range, you may thin your water and, thereby, lower carbonate hardness by adding rain water.

NO₃-Nitrate

Nitrate is a fertilizer stimulating the growth of plants. An increase in nitrate will inevitably lead to additional plant growth. This increase in nitrate will result in murkier water caused by algae blooms. As a consequence, the biological balance in your pond will be disturbed. Dead algae will sink to the ground and decomposed by micro-organisms at high levels of oxygen consumption. This decomposition will release more nitrate (the nitrate predefined in the plants' cells), which will result in an even higher growth of algae. This process can only be interrupted if the micro-organisms of the biological filters of your Multi-Pond manage to decompose the nutrients into their own biological mass or the nitrogen in the air, which is unavailable to the plants.

Nitrate is a preliminary end product of protein decomposition and develops during the step-by-step decomposition of ammonium and nitrite. Nitrate is formed during nitrification (biological reconstruction) by the degradation performance of the second-order nitrificants (micro-organisms). In contrast to ammonia and nitrite, nitrate is not poisonous. Therefore, it does not pose an immediate threat to humans (swimmers) or the organisms in your pond.

Due to today's overfertilisation of fields, large amounts of nitrate are increasingly found in groundwater (especially in rural areas). Concentrations of up to 200 mg per litre are no rarity. Ideally, your Multi-Pond should not contain more than 10 mg of nitrate per litre.

Excessive concentrations of nitrate may gradually reduce the effectiveness of your pond's filter system. Plants, too, consume nitrate. If you detect nitrate concentrations of 10 mg/per litre or more, make sure not to add any more fertilizer when planting more plants in your Multi-Pond.

PO₄-Phosphate

The total phosphate concentration is considered a soiling factor for water. Phosphate is a plant nutrient and may affect the growth of plants in waterbodies. As phosphates are often added to potable water to provide protection from corrosion, tap water may often contain high concentrations of phosphate.

Ideal value: < 0.01 mg per litre

Measures: Biologically, phosphates cannot be filtered out sufficiently. Ways to eliminate them are precipitation processes and binding. Large amounts of phosphate may result in an increase in algae formation (green water). Reduce phosphate concentrations in the filler water by adding suitable phosphate binders.

Let's get to work

Prepare your dig

Before starting to dig your Multi-Pond, you should separate the valuable top soil from the rest of the material to be excavated. You will usually want to remove the existing turf from your lawn. After that, remove the top soil. It is often useful to store this soil on the side to later use it for soil moulds, flower beds, etc.

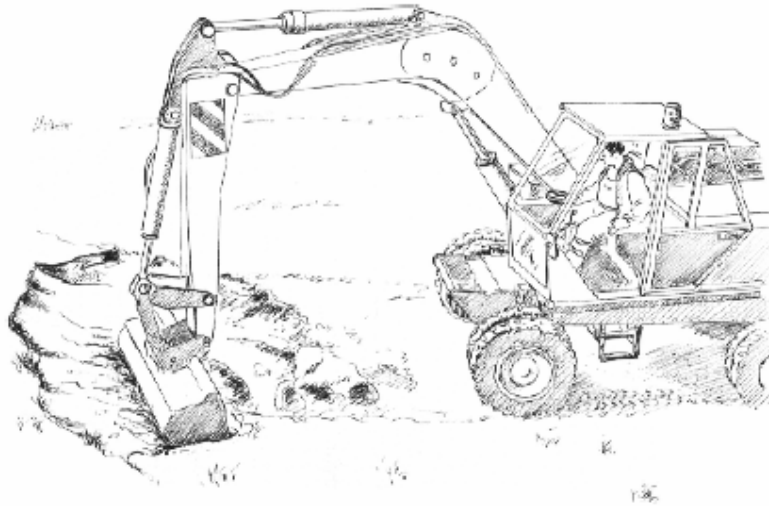

Fig.: Removing the grass turf

Peg out the Multi-Pond

You can now proceed by pegging out the outer dimensions of your Multi-Pond area. You should dig the excavation bottom approx. 18" larger than the (50 cm) zone on all sides. As you will not be able to dig the pool walls vertically, we recommend sloping the soil walls by 75 degrees. This will result in an enlargement of the excavation surface. Mark the established area using chalk, dowels or similar tools.

Excavate the Multi-Pond

You can now proceed to excavate the pool.

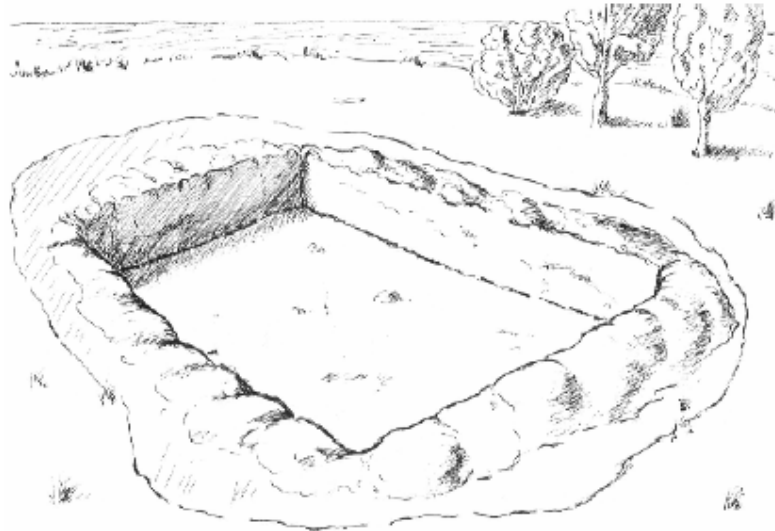

Fig.: Excavated pit

In most cases, you may want to dig your pit up to the height of the bottom. Dig the subconstruction for the wall elements in a second step. If groundwater is present, dig the pit deeper and take the steps necessary to protect the pit against groundwater seepage (e.g. drainage, lance flushing, etc.).

You will usually not have to further seal the bottom when digging in naturally grown soil. However, since the top layer will be loosened by the excavation, we recommend using a vibratory plate to perfectly even out the subsurface.

Strip footing

Now, use a shovel and/or a spade to dig a narrow ditch at the bottom of your construction pit, into which you will later insert the wall elements. This ditch should be approx. 6" wide and 10" deep.

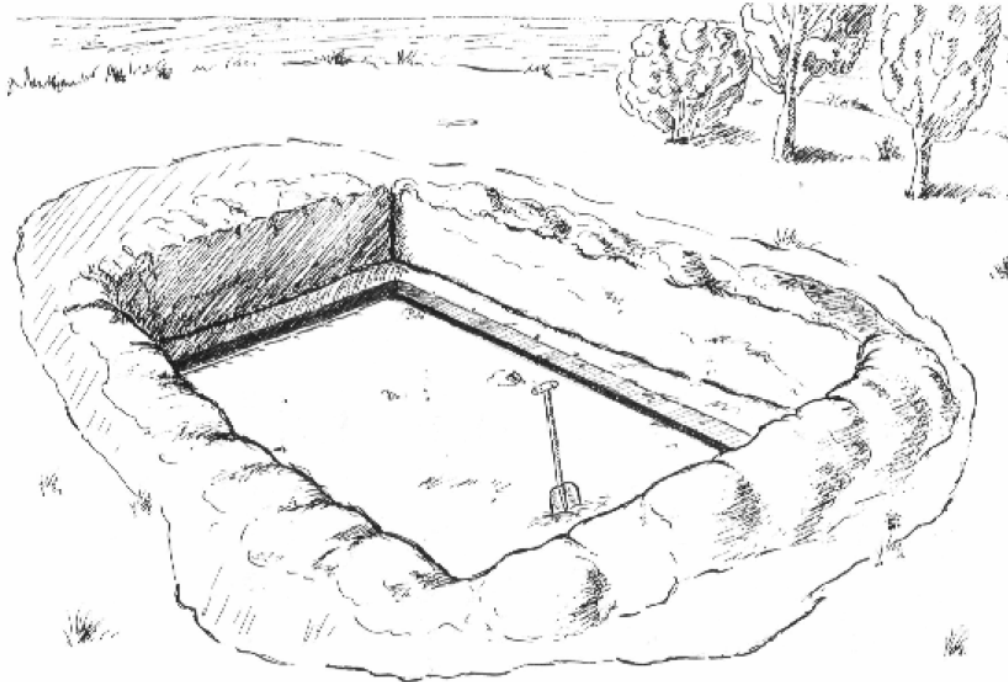

Fig.: Completed excavation including strip footing

Use the following simple auxiliary construction to set up and perfectly align the wall elements: The wall elements (width: 39"; height 41.5") can be set up more easily if they can be placed onto an even / horizontal subsurface. To "simulate" such a subsurface, use individual paving stones and place them one meter apart from each other in the strip ditch. This will ensure that they will later be centrally located underneath the wall elements. Individual paving stones can be aligned in a quick and easy way on a layer of fine aggregate material and dry plaster. Once you have set the stones, proceed with the construction of the wall.



Fig.: Construction aid paving stones

The Deep zone

Setting up the wall elements

When setting up the wall elements, start on one corner. To connect the elements around the corner, use special corner profiles and screw them together. Use a cordless drill with a 10mm socket on the screws.

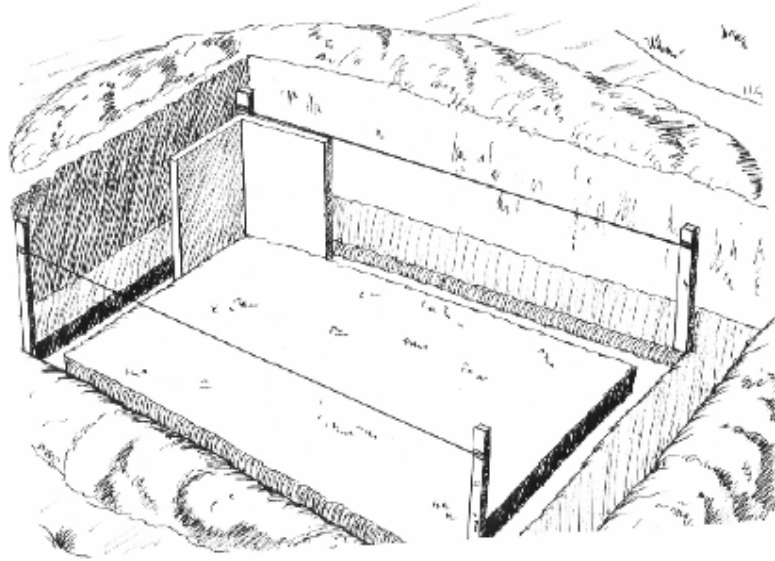

Fig.: Inserting the first wall elements - started on one corner.



Once the first corner has been set up, set the successive wall elements up in a row. Connecting the elements is easy thanks to the elements' groove and tongue fittings. As soon as groove and tongue are connected and aligned, simply screw the walls together using the screws included with your Multi-Pond. This is best done as a team effort: one person will push the set up wall element properly into groove and tongue, while the next person screws the parts together.

You will have to practically insert the last element into the remaining gap from above. Two people can perform this task in a snap.

Attach profiles to the top of the wall elements you set up to stabilize the entire framework. All necessary screws and nuts are included with your Multi-Pond.

The following pages include detail and function drawings referring to the corner connections. Refer to these drawings for the exact arrangement of the profiles and their bolted connections.

Once walls are installed and all corner braces are in place, corners should be taped to protect liner.

Important:

Make sure to check the installation height of the wall elements! The installation depth is **8.75"** below the deep zone base. The reason why it is essential to observe this information is that the pond liner allows only the slightest variations in installation height. You may otherwise

damage the pond liner for good, as it will be subject to uneven wear, for which we cannot assume any liability.

Please ensure the wall detail below is followed with respect to the corners.

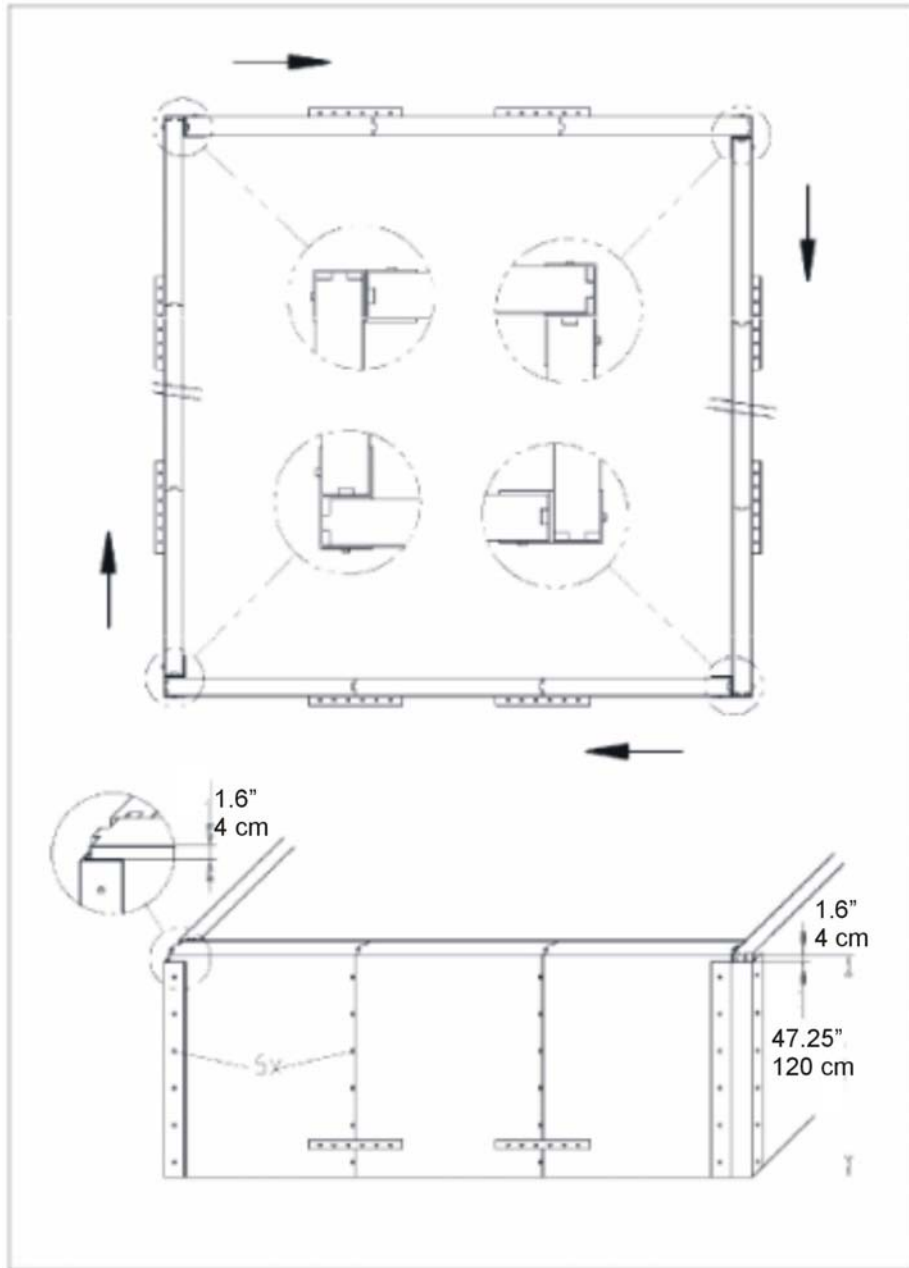

Fig.: Corner profiles and transverse joints

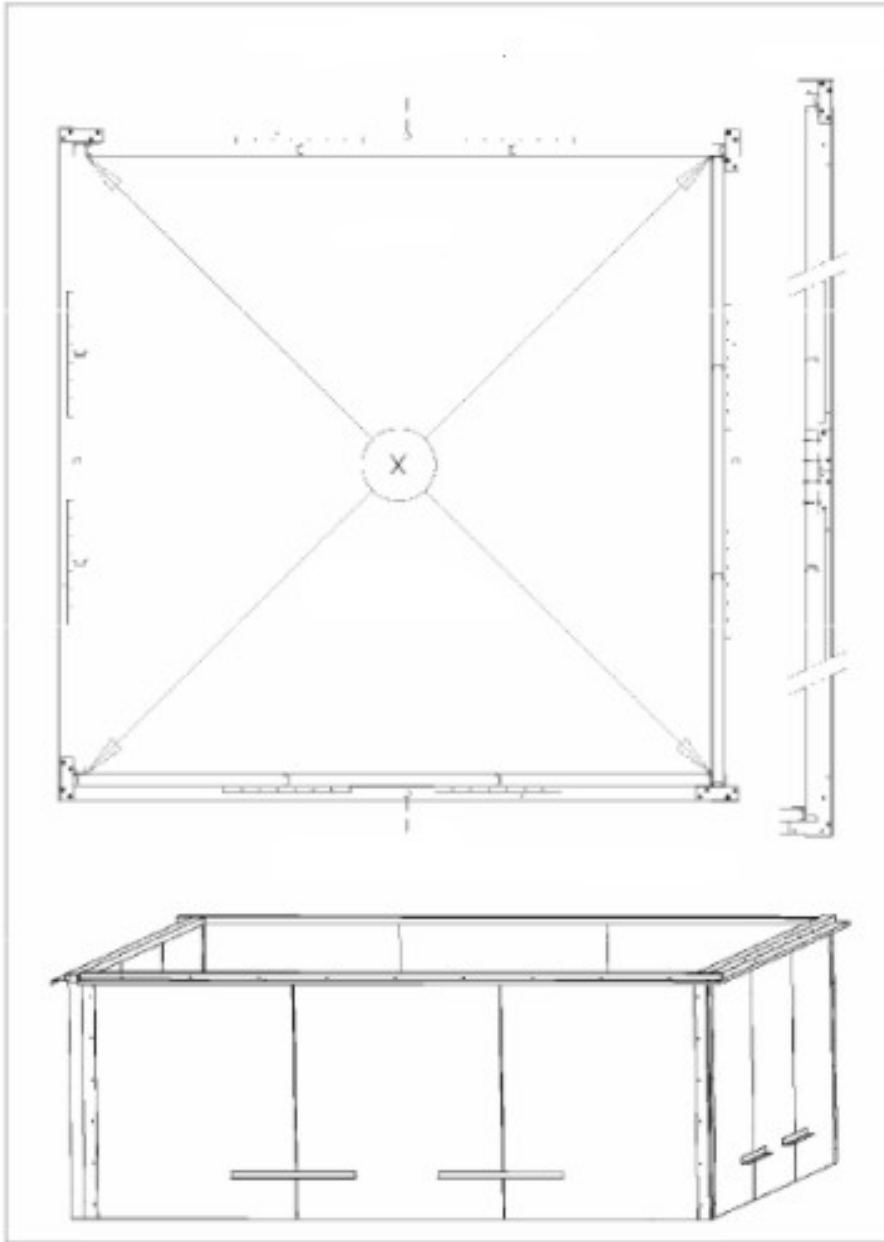

Fig.: Installing the edge profiles

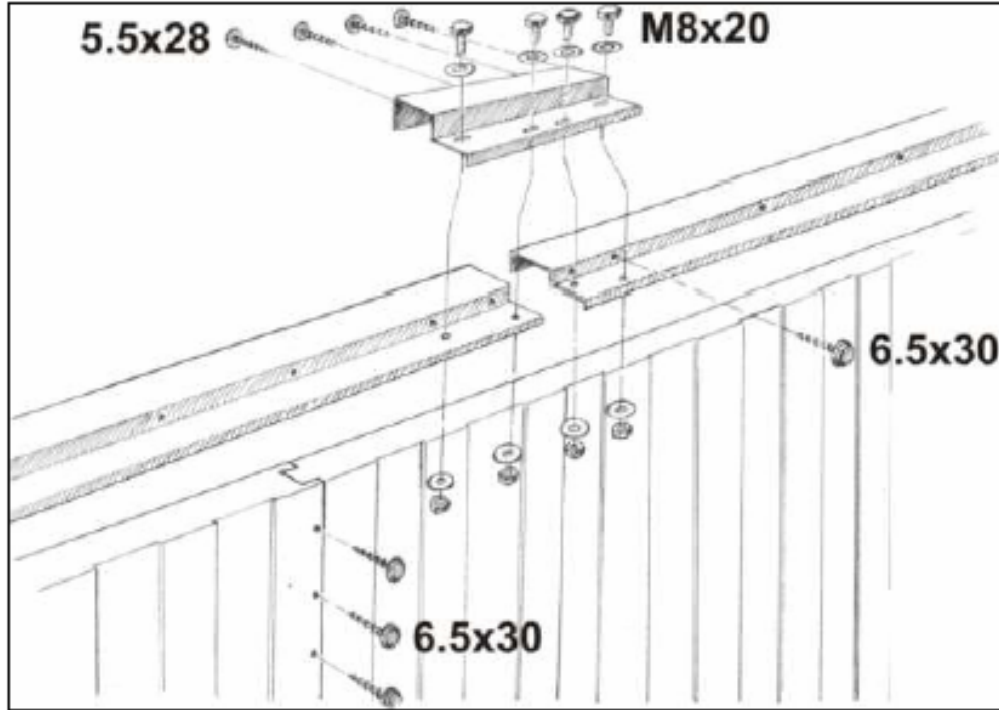

Fig.: Auxiliary drawing showing the bolted connections of elements and profiles

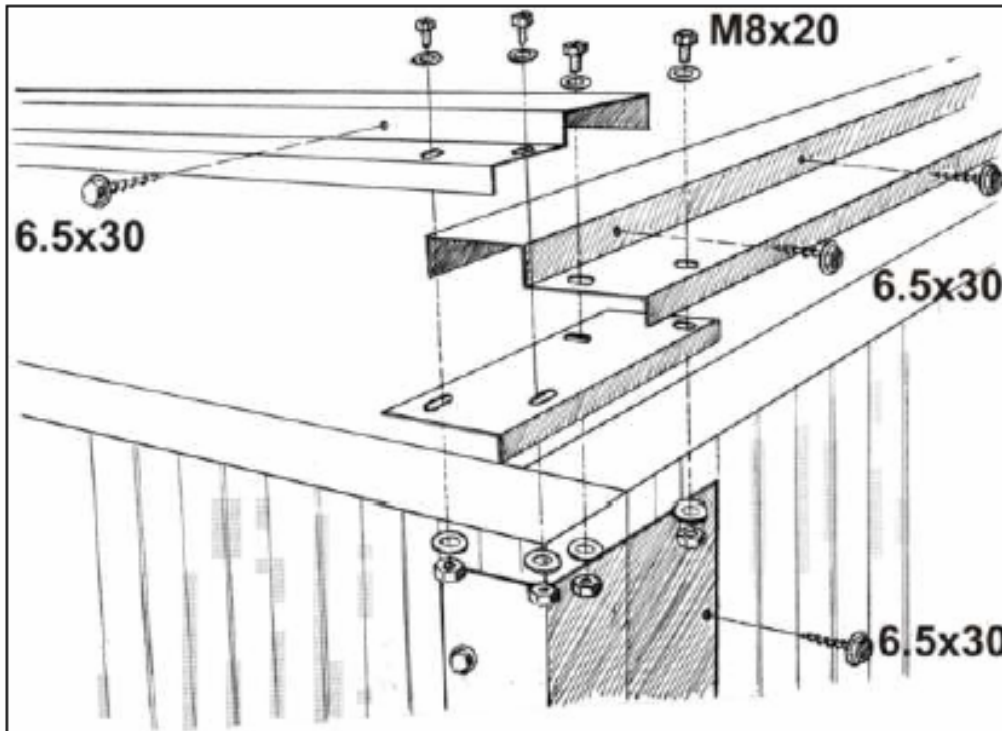

Fig.: Auxiliary drawing showing the bolted profile connections in the corners

Aids for crossbracing

Any distortion in the frame, which is made up of the wall elements and the profiles, must be prevented. Distortion can be caused by excessive pressure when filling and sealing soil in the future regeneration zones. To minimize this risk, integrate the following simple auxiliary construction: wooden cross beams. Insert these beams into the frame and remove them at the appropriate time. They will be used on several occasions throughout the construction process.

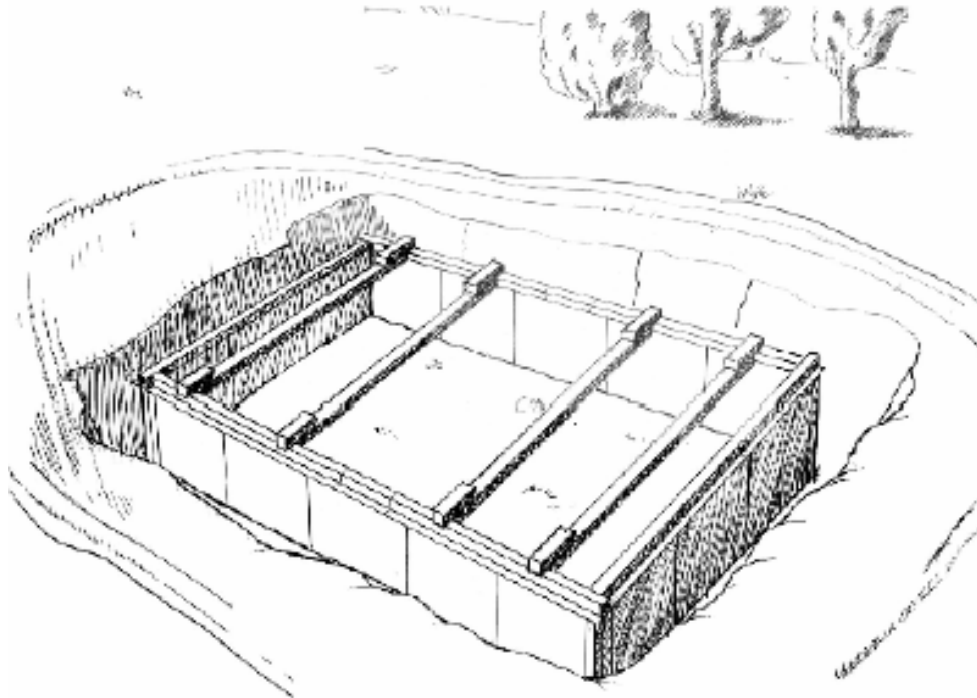

Fig.: Completely set-up frame including indicated cross beams

The cross beams are supposed to provide an initial tension of approx. 6". For more information, please refer to the drawing on the next page of these installation instructions.

Bracing aids

Instead of using cross beams, you may also use wire, driving pegs, and wire stretchers to brace the wall construction outward (once on the center of the short sides, twice on the long sides). The tightened wire may be attached to the steel profiles.

Neither of these aids – cross beams and bracing – are included with your Multi-Pond kit.

Swimpond dimensions 16' x 10'
5m x 3m

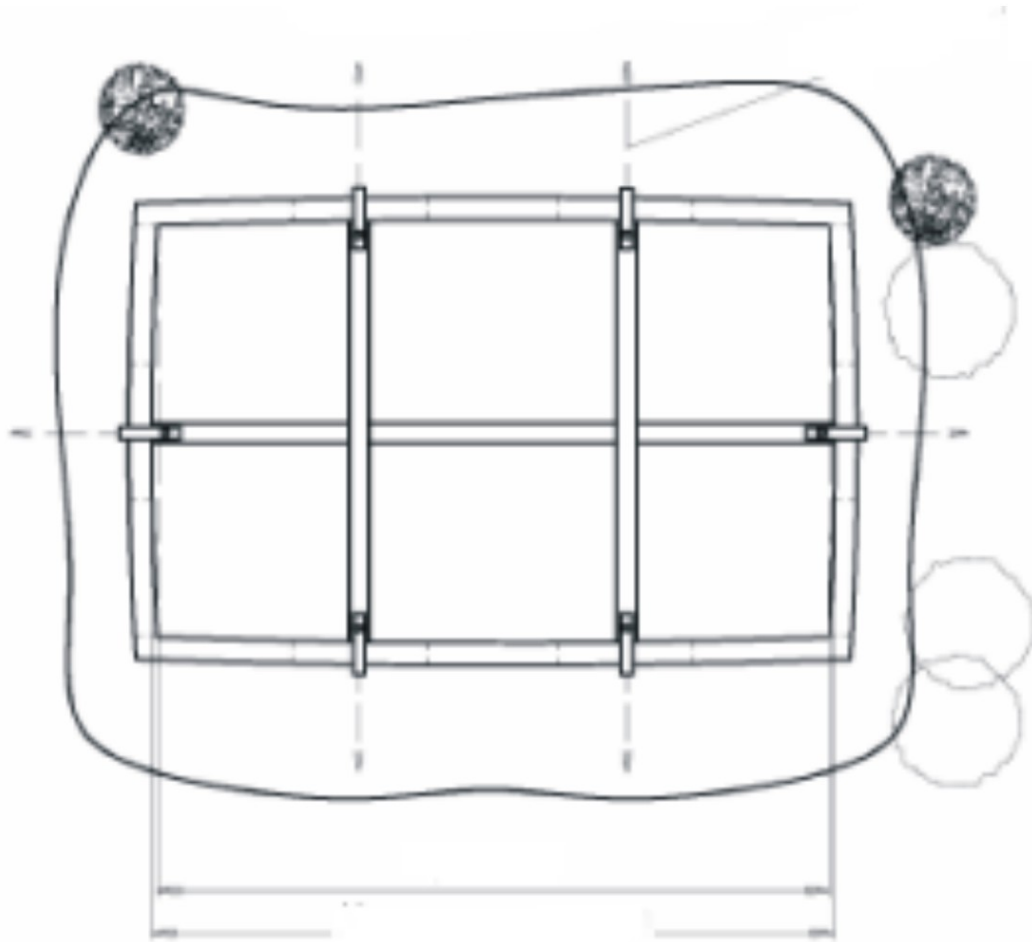

195.6" (497 cm) inside wall measurement & brace length
116.9" (297.45 cm) inside wall measurement & brace length

Fig.: Auxiliary construction cross beams

Filling and sealing the soil, part 1

Before placing the pond liner in the deep zone area, you should fill the corners outside of the deep zone with soil in a layer of approx. 20 cm in thickness and preliminarily seal it by stamping your feet on the soil. Later, after inserting the pond liner, the degree of compression in this area and in the area around the deep zone will be further increased thanks to the filled-in water.

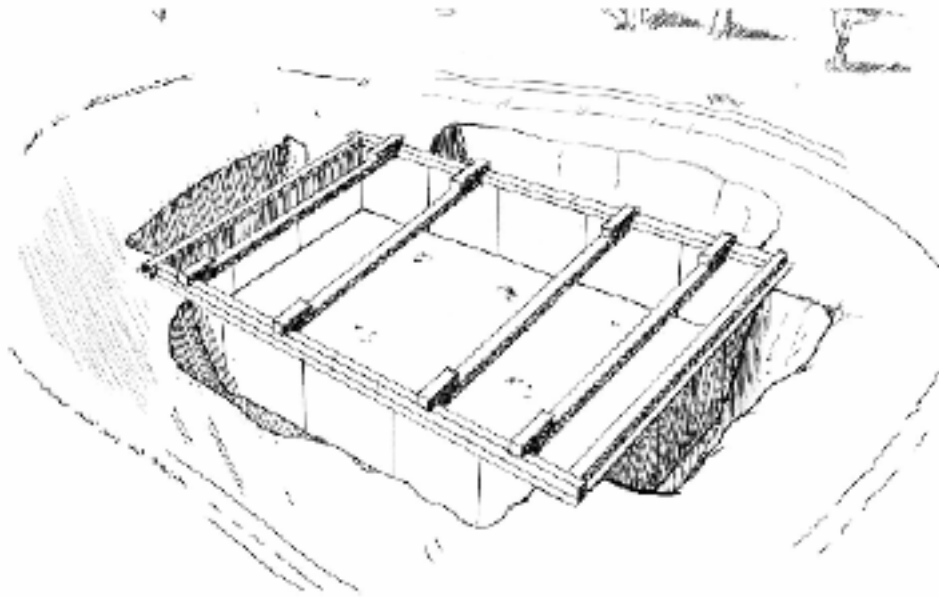

Fig.: Start at the corners when filling the soil in

Working on the pond liner, part 1

Spread the protective fleece below the pond liner

Before inserting the pond liner, spread a layer of protective fleece **in the deep zone, wall, and steel profile area**. Instead of using the fleece on the entire wall surface, cover only a little less than half of the wall surface (see fig.).

Before doing so, search the sole of the deep zone for stones, branches or similar waste. Remove any hard or sharp objects. At a later stage, line the entire shallow area of your pond with protective fleece. This will protect the pond liner against any damage from below. The individual fleece lanes should overlap by approx. 4".

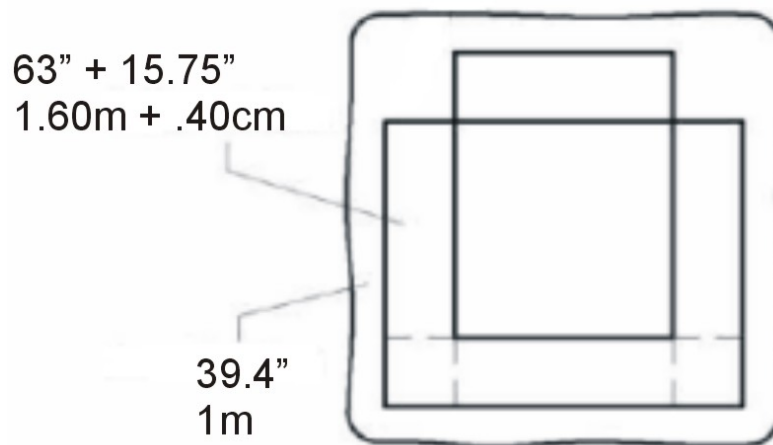
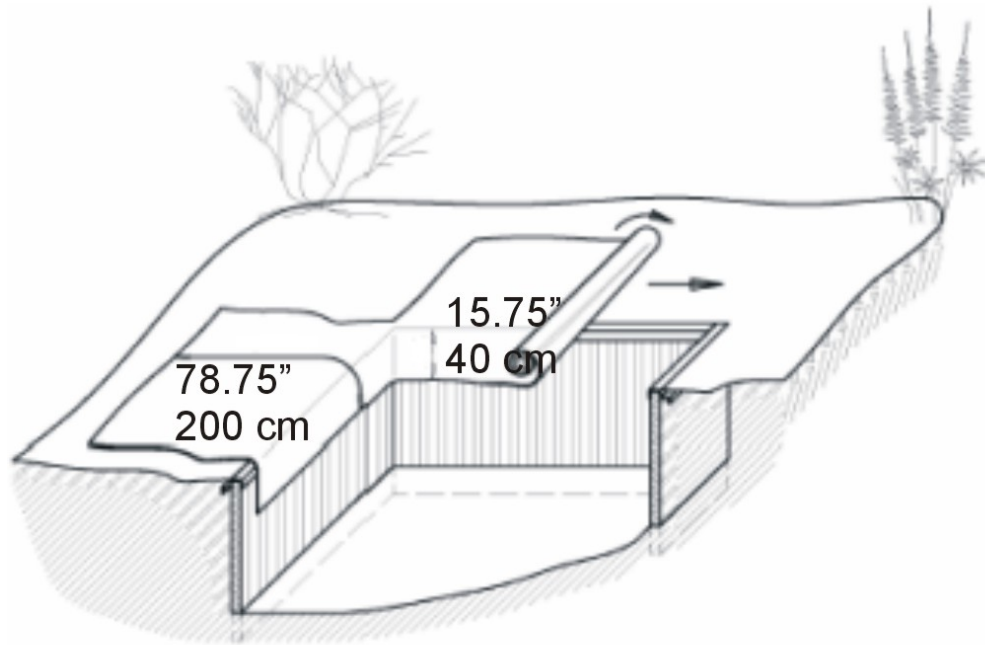

Fig.: Preparations for laying the pond liner

Hanging the pond liner bag

Prior to further filling the area around the wall construction, you should place the pond liner bag in the deep zone and fill it with water, while continuing to fill the pond with soil. Make sure the water level inside the deep zone is 10" higher than soil level on the outside. This will create an important compensating pressure stabilizing the frame from the inside, while the filled and sealed soil exercises pressure on the construction from the outside.

Six adults should be able to easily move, spread, and insert the pond liner bag. Start by unrolling it lengthwise and place it across the centre of the pool and the cross beams. Now, unfold the bag further to the side until the square you insert into the deep zone fits on the cross beams as accurately as possible.



Fig.: The liner bag is first placed onto the centre of the auxiliary beams

Now, two people lift the pond liner to a height that will allow a third person to retrieve the cross beams from underneath the liner. The bag is thereby lowered further and further into the pool area.

Once this step has been completed, adjust the liner until it is almost completely void of all creases. For this purpose, one person may enter the pool area to cautiously support the adjustment of the liner, in particular in the corner areas, by using his or her feet.

Note:

Make absolutely sure that the protective fleece is situated on top of the frame's steel profiles underneath the liner, especially in light of the fact that the liner is dragged and shifted.

In doing so, you will prevent the liner from becoming damaged.



Fig.: Protective fleece functioning as a cushion

Remove the cross beams only briefly when lowering the pond liner into the deep zone. Reinstall the cross beams as soon as you are done inserting and adjusting the pond liner bag. The beams are now to be set on top of the liner. Before doing so, cut out a few pieces of protective fleece and place them between pond liner and beam so that they can function as a cushion to protect the liner against any damage.

The all-around liner sleeve used for creating and sealing the shallow zone is folded inwards across the wooden beams to prevent it from obstructing the way during the earthwork and the filling of the outer zone. It will not be unfolded completely until the fine plane of the regeneration zone has been formed, sealed, and also lined with protective fleece. Before adding water to the deep zone, smooth out liner as much as possible.

Filling and sealing the soil, part 2

Keep filling soil in layers of approx. 10" in thickness all around the pond while water is flowing into the deep zone area.

You may not use tools such as a rammer or even a vibratory plate in the immediate vicinity of the deep water zone (19.75") to compress the soil. This may cause the frame to shift during the construction of the wall. As a consequence, use your feet to coarsely compress the soil before flushing with water. Although this process may take longer, it is the easiest and safest way to compress the soil in this area.

Be very careful, yet thorough when compressing the soil. Any soil settling after completing construction will subject the liner to unnecessary stress.

Connection pond edge / wall

Shaping the future shallow areas of your pond

Every step of the soil filling and compression process helps create the future regeneration zone of your pond as well as the so-called fine plane. Fine plane (from Latin planum = surface, level), in this case, is defined as the completely shaped level of the surrounding regeneration zone. The cross section (see below) shows you exactly how to shape this level. After building the capillary barrier, as described in the following section, create and compress another 1-1 1/4" thick sand layer. This layer of sand will later provide additional protection for the pond liner you need to install.

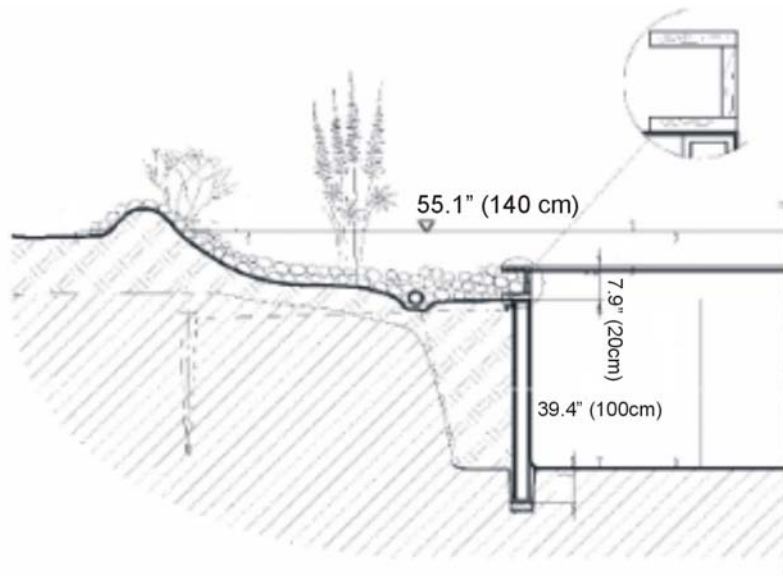

Fig.: Cross section through the regeneration zone

Building the capillary barrier

The "edge" of every pond is formed by a capillary barrier, which also gives the pond its outward shape. It prevents water from accidentally seeping in and out of the pond. To build the capillary barrier (edge of the pond), prepare the edge of the pond appropriately. We recommend building your capillary barrier 4" high. This means that you will also have to level the area 4" below the edge if you want to place the edge of the pond there.

There are several ways to shape a capillary barrier/pond edge. The easiest way is to shape a soil bulge permanently fixed with lean concrete.

A similarly effective way is to use stones (e.g. paving stones cut in half) placed in a bed of mortar.

Dowels are often driven in around the shallow area at a distance of 15.75". The dowels are used to mark the planned height of the capillary barrier. A PE strip fixed with Spax screws is attached at this height facing the pond. The dowels are later cut off to the rear (away from the pond) with a jigsaw so that you can later lay the pond liner across these spots without damaging the liner. This method is shown in the above cross section through the regeneration zone.

After completing the edge of the pond (capillary barrier), make sure to search the shallow area for stones or other debris. Remove any debris immediately to prevent the pond liner from becoming damaged.

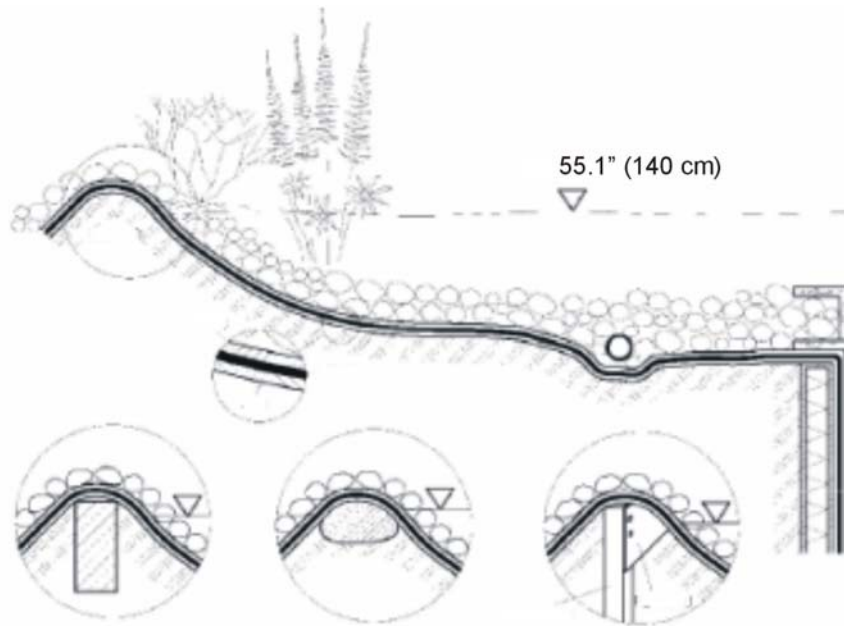

Fig.: Shaping the capillary barrier

Creating the pond spillway

The purpose of a pond spillway is to drain any excess pond water in a controlled fashion. There are two ways to create a pond spillway:

For draining sub-surfaces

In this case, every 39.25" of the edge of the pond is lowered or shortened by approx. 4". You will then dig out a hole of 39" x 39" behind this edge. Next, line the entire surface of this hole with a piece of protective fleece to provide a separating layer. Finally, fill this hole up to the top edge of the pond with draining material such as gravel.

Tip:

Do not fill the hole with gravel until the pond liner has been laid.

For non-draining subsurfaces

Dig a hole as described under (1).

In addition, insert a spiral coconut-clad drainage pipe into the hole (approx. 7.75 - 8" above the bottom of the hole). Make sure that this drainage pipe is laid at a slope leading from the hole to the drainage ditch, where it must be connected. Cover the drainage pipe along its entire length with a layer of draining material.

Now, integrate a layer of fleece that can function as a separating layer. Finally, fill in soil.

Spreading the protective fleece further

After completing the regeneration zone and the capillary barrier, evenly spread out a layer of protective fleece in these newly created areas. This will protect the pond liner against any damage from below. Once again, search the surface for any sharp objects, stones, and branches, and remove them. The individual fleece lanes should overlap by approx. 4".

Working on the pond liner, part 2

Spreading the pond liner all the way

You can now completely unroll and straighten the pond liner. Thanks to the weight of the water that is already contained inside the deep zone area, the position of the pond liner can no longer shift.

Spread out the pond liner across the capillary barrier (approx. 30 to 50 cm) as smoothly and crease-free as possible.

Even more protective fleece

After that, lay yet another layer of fleece on top of the pond liner spread out in the regeneration zone to protect the liner against any damage from above, for instance, by gravel or other loads. Make sure to lay the fleece all the way to the edge of the Multi-Pond area!

Before pouring the gravel

Installing the wooden border of the Multi-Pond zone

Place the wooden boxes on the edge of the pool wall and make sure that there is protective fleece underneath them. Position the boxes flush with the edge of the deep zone. To ensure that the fleece will not be visible later on, simply drag it back a little bit (by approx. 1/2"). Now, screw the boxes together such that they form a stable square. Please use only the included stainless steel screws for this purpose. The boxes, which are open to the back, will later be filled with gravel.

You will, again, be using the cross beams to prevent the wooden frame from deforming when filled with gravel.

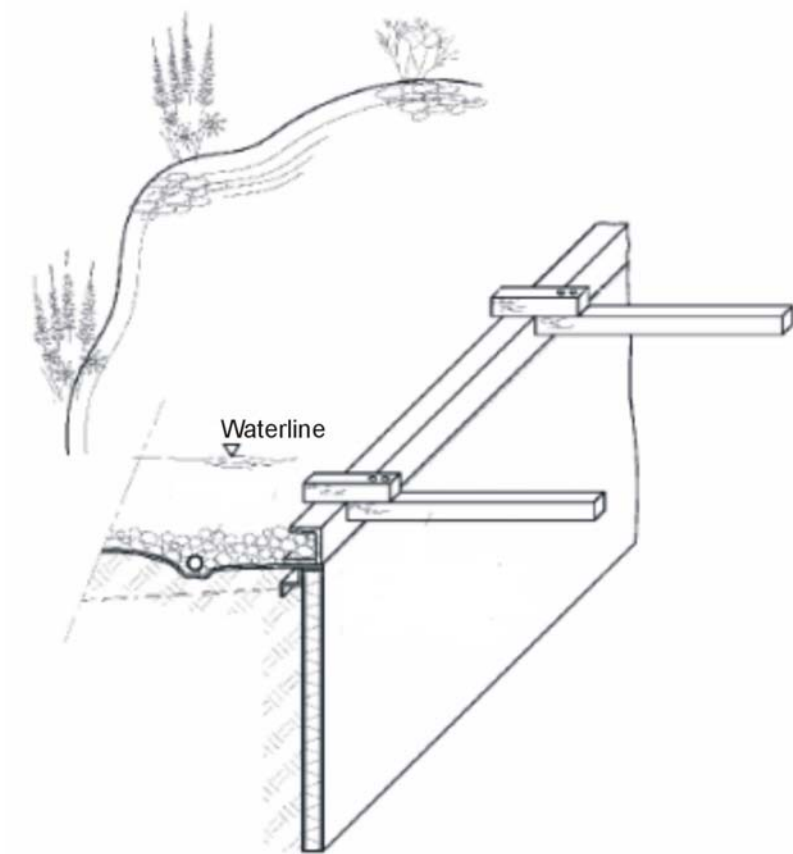
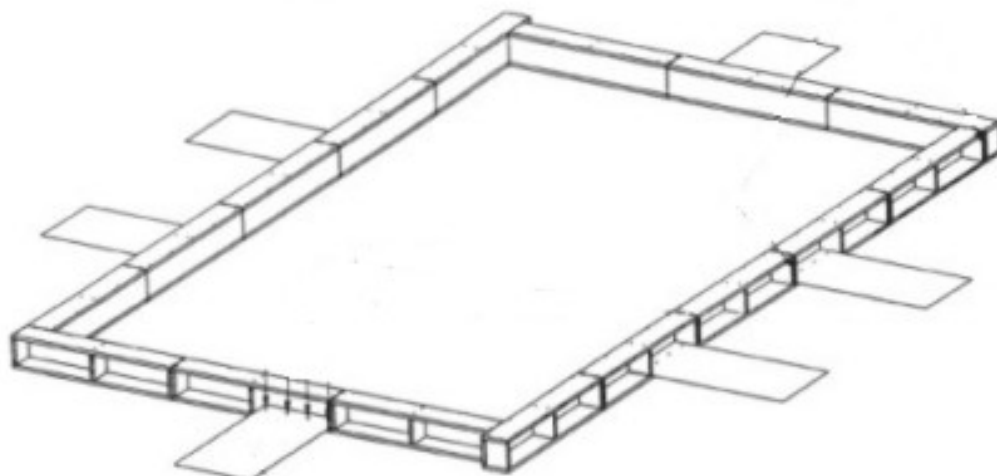

Fig. 1A: Position of the wooden boxes

Using the 6 pieces of liner supplied and the packaged screws, screw liner to boxes. When gravel is added on top of liner pieces they help to secure boxes from moving.



The pipeline kit

Included with your Multi-Pond kit is the entire pipeline including its fitting as well as all necessary cleaners and adhesives.

Pipeline kit consisting of:		Multi-Pond Set 3 x 5
Drainage pipe DA 50	[ft]	90
Swimflex pipe DA 50	[ft]	20
Bushing DA 63 / 2"	[units]	2
T-piece PVC	[units]	1
Double adhesive flange	[units]	2
Tangit adhesive 500 ml	[can]	1
Tangit cleaner 1,000 ml	[can]	1

Positioning the filter system

We recommend that you install the filter system where you later want to set up the included wooden deck. In doing so, the system will become virtually "invisible," as it will disappear under the boardwalk (if you want it to).

Select a spot of your choice and dig a sufficiently large hole. The filter outlet should later be located approx. 15.75" (40cm) away from the deep water zone!

If you want to, stabilize the pit you dug with encasing. However, the filter container will be able to withstand the pressure exercised by the soil without any additional help.

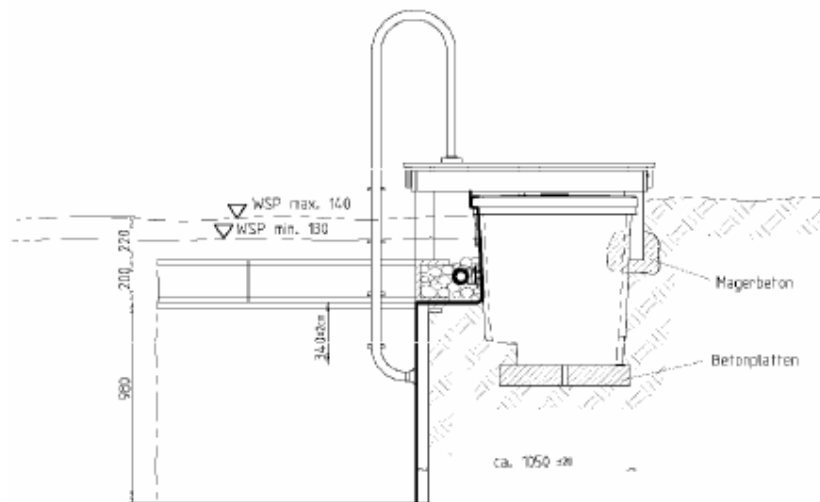

Fig.: Filter position

Installing the filter

You can now lower the filter into the pit and flange it to the pond liner. The height of the filter container must be aligned such that future water levels will not reach above the skimmer opening. Ideally, water levels should not exceed the lower half of the opening (see drawing above). Once you have found the correct position for the filter, drag the pond liner vertically in front of the filter and attach both the flange for the skimmer opening and the filter outlet. Make sure to have extra folds in liner to avoid any pulling that may happen if shifting occurs. Finally, cut out the inlet and outlet openings.



Fig.: Flanging on the skimmer flap

Laying and connecting the pipes

You must now lay out and install an all-around drainage field on the protective fleece in the shallow area of your pond. This field is composed of a DA 50 drainage ring (yellow, slit pipeline).

Start by screwing the included T-piece to the filter outlet. After that, glue the two bushings (DA63 → DA50) on to the right and the left. Before you do so, make sure that the gluing surfaces are dry and free of any dust and grease. Thus, use the Tangit cleaner first before applying the Tangit adhesive. Both items are included with your Multi-Pond set. Please follow the instructions for both the cleaner and the adhesive!



Next, attach an approx. (1.50 meter) long piece of the gray PVC pipe to each of the outlets. To establish the connection to the yellow, slit drainage pipe, use the double adhesive flange (DA 50). Glue each end of the flange to the corresponding end of the (3 m) piece of the PVC pipe.

You can now lay the drainage ring all around your Multi-Pond zone and close the pipeline system by glueing the drainage pipe to the DA 50 double adhesive flange. Please follow the instructions for both the PVC adhesive and the cleaner when glueing the T-piece to the pipeline.

Gravel integration

Gravel heaps with a function



The gravel heaps serve an additional purpose. The drainage pipes press the filtered water from the filter system into the lower gravel layer. Once it has reached this layer, the water – just as in the filter – will be pressed, first, through the coarse gravel and then through the fine gravel. This will clean the water even further. Before integrating the gravel filter layers, weigh down the drainage pipes you installed as well as the fleece to prevent them from "floating up" when the gravel is poured.

You can now proceed to pour the gravel layers. You should only use washed gravel with a pure grain.

You will integrate 3 layers of gravel with 2 different grain sizes: Washed round gravel $\frac{1}{4}$ " (2/8 mm) (e.g. Pea gravel)

- Washed round gravel $\frac{1}{2}$ " (8/16mm) (e.g. Pea gravel)

Please do not use any sharp or unwashed gravel grains or sea gravel. You will probably want to view the gravel at your local building material store before you decide which kind is best suited for use with your pond.

Three layers of gravel

Layer the gravel in the shallow area up to the edge of the pond. Pour the bottom layer of $\frac{1}{2}$ " (8/16 mm gravel) in a $3 \frac{1}{4}$ " (8 cm) thick layer, the medium layer of $\frac{1}{4}$ " (2/8 mm) gravel also in a $3 \frac{1}{4}$ " (8 cm) thick layer, and the top layer of, again, $\frac{1}{2}$ " (8/16 mm) gravel in a $1 \frac{3}{4}$ " (4 cm) thick layer.

The wooden deck

Delivery condition

The wooden deck, which can be used both as a sun deck and to hide your filter from sight, is shipped in four parts: a completely assembled subconstruction, two halves of a boardwalk, and a board. The board will not become relevant until you install the ladder.

Assembly

The wooden border of the deep zone is used as a support structure for the two poles of the subconstruction. Lower the two rear poles into the ground up to the same height or anchor them appropriately to a level subsurface. We recommend that you build a small concrete foundation. Place the two halves of the boardwalk on the frame and screw them on tightly. To keep the filter underneath the deck accessible, you should attach some hinges (not included).

Planting recommendation

The following recommendations list only a few of the countless plants that you may consider for your Multi-Pond. Talk to a plant expert of your choice to compose the right set of water plants best suited for your Multi-Pond.

Water plantain

Well-known water plant with mostly spoon-shaped, long-stem 40 cm leaves. Panicle, lively, storey-like structured inflorescences with white blooms. Marsh plant; water depth – 11 ¾" (30 cm), height 23 ½" – 31 ½" (60-80 cm), colour of the blooms: white

Rannoch rush

One of the most beautiful water plants. Large, attractive flower umbels with pink, sometimes white individual blooms with red veins. The leaves are ½" (1 cm wide), linear, three-edged. This plant loves nutritious soil. Marsh plant; water depth – 15 ¾" (40 cm), height 31 ½" (80 cm), colour of the blooms: pink

Marsh marigold

The marsh marigold is a widely known waterside plant and falls into the category of early bloomers. Its gold-yellow blooms glow even in the shadiest conditions. It will primarily grow on wet, nutritious, mouldy, and clayey soil. Marsh plant; water depth 0 – 4" (10cm), height 11 ¾" – 19 ¾" (30-50 cm), colour of the blooms: yellow gold, bloom III-V

Water avens

Water avens have nodding, red umbel clusters. They are especially well-suited for brooks and watersides. Marsh plant, height 11 ¾" – 23 ½" (30-60 cm), colour of the blooms: red, bloom IV-VII

Japanese iris

The Japanese iris is able to stand in shallow waters all year around. As it does not grow as tall as *I. Pseudacorus*, it is well suited to be planted in water gardens. Its blooms are a rich blue and have a yellow middle stripe on their hanging leaves. Marsh plant; water depth 0 – 4" (10cm), height 27 ½" (70 cm), colour of the blooms: Rich blue with yellow stripes on its hanging leaves.

Yellow flag

This indigenous water or yellow flag lily is often found in ditches and marches in Europe. It has a multi-bloom pedicle, and its leaves are sword-shaped. As it constantly wants to spread, it is only suited for larger ponds. Marsh; water depth 0 - 15 ¾" (40 cm), height 39 ½" (100 cm), colour of the blooms: yellow, bloom V-VI

Firecandle

The firecandle is a beautiful indigenous plant. This plant loves moist places and wet watersides and can even stand in the water. It does not form any tillers and is, therefore, well suited for water gardens. Marsh plant; water depth 7 ¾" (20 cm), height 19 ¾" – 39 ½" (50-100 cm), colour of the blooms: pink, bloom VII-IX

Watermint

Just as the popular peppermint, the watermint blooms with pale purple bloom crowns in the upper axil. It has fresh, overflowing green or red leaves, which have an aromatic scent. They are even suitable for tea preparation. As the plant tends to spread out, it needs to be cut back on a regular basis. Marsh plant; water depth 7 ¾" (20 cm), height 23 ½" (60 cm), colour of the blooms: purple blue, bloom VII-X

Monkey flower

The monkey flower is an attractive waterside plant suited for moist and wet areas. The luminous blooms of this permanent bloomer are trumpet-like. When touched, its stigmata fold up within seconds. This low-maintenance plant flourishes both in wet and dry zones; marsh plant; height 15 ¾" (40 cm), colour of the blooms: yellow, bloom VI-IX

Water forget-me-not

Sky-blue, yellow-eyed blooms in loose inflorescences, similar to those of the garden forget-me-not. A fully persevering plant. Marsh plant, height 7 ¾" - 11 ¾" (20-30 cm), colour of the blooms: red, bloom V-VIII

Arrow head

The Sagitaria arrow head is a well-known indigenous plant, which grows mostly on river banks and distinguishes itself by its typical arrow-shaped leaves. It is highly adaptive and can survive even in different water conditions. Marsh plant; water depth 11 ¾" - 15 ¾" (30-40 cm), height 23 ½" (60 cm), colour of the blooms: white

Lakeshore bulrush

The lakeshore bulrush will flourish even when planted in deep water. It has whip-shaped, overhanging, dark-green, and (at the base) thumb-thick stems. A highly decorative plant suitable for larger ponds. Marsh plant; water depth 31 ½" (80 cm), height 78 ½" (200 cm), colour of the blooms: brown.

Graceful cattail

Its leaves are strikingly narrow. They are arched at the top, almost semicircular. Its spadices are egg-shaped. Its male bloom spike is almost three times as long and has a distance of several centimetres. Marsh plant; water depth 11 ¾" (30 cm), colour of the blooms: brown; bloom VI-VIII

Dwarf reedmace

The dwarf reedmace is a petite plant with very narrow leaf sprouts. Its brown spadices are spheroidal-elliptical. Its bloom spike is somewhat distant and approx. of the same length. It bears its spadices early, but also loses them already in late summer. It is particularly well suited for small ponds and water tanks. Marsh plant; water depth 4 - 7 ¾" (10-20 cm), height 23 ½" (60 cm), colour of the blooms: brown; bloom V-VI

American waterweed

Although the waterweed spreads out far, it is also a good source of oxygen. It multiplies vegetatively. Underwater plant; water depth 7 ¾" - 39 ½" (20-100 cm)

Yarrow

At low water levels, the parrot's feather grows 4" (10 cm) above the water. With its lightgreen, fir needle-shaped leaves, the plant forms a feathery lawn. At higher water levels, the plant floats on the surface. Its blooms are rather plain. Underwater plant; water depth 11 ¾" (30 cm) or greater; colour of the blooms: pink, bloom VII-X

Water lilies

There is an incredible number of colour variations in water lilies. Any colour imaginable is possible – from white to pink to the darkest red, from yellow to orange to the darkest copper hue.

The smallest kinds have blooms that are 1" (2.5 cm) in diameter (such as the "Helvola" species). When planted at the right depth, the "Gladstoniana" species is a giant with bloom diameters of up to 10" (25 cm). The space requirements of these plants vary with their bloom sizes.

Planting**Filling the deep zone all the way to the shallow zone**

You can now go ahead and fill your Multi-Pond with plants. Try to pick plants that do not necessarily require you to plant underwater.

You will then fill your Multi-Pond up to its overflow edge.

What do you have to keep in mind during planting?

Most waterside and water plants require well-lit locations to flourish. You should keep this in mind – not only during planting. Late shading caused by growing trees may also affect shallow water vegetation.

By introducing a large variety of species into one eco system, you are allowing your pond to continuously change based on self-selection. More often than not, some water plants do not like their new location at all and, consequently, wither and die.

Warm water temperatures have a favorable effect on the growth of water plants. The best time to plant new water plants is between May and the end of July. Plants planted during this period will often flourish by the beginning of the fall. When planted earlier or later, plants will develop more slowly. That said, water plants can generally be planted all year long. However, you should consult your garden plant supplier to inquire if the plants you choose will also be available in the winter time.

When planting water plant, please make sure the planting soil in the container is not overfertilized. Should you discover many fertilizer balls on the surface of the planting soil, make sure you remove all of them. When planting water plants in your Multi-Pond, place them in a nutrient-poor substrate. Please use planting substrate only for the washed gravel required in the regeneration area.

Start by setting up the water plants according to a planting plan established by yourself or an expert. As a next step, prepare a planting hole in the gravel using a small trowel or your hands (about 2-3 times as large as the plant cluster) and set your water plant in this hole. After that, fill the planting hole with the fine gravel (grain size $\frac{1}{4}$ " or 2/8mm).

When planting water lilies, you may want to fill the planting hole with washed sand to promote quick growth.

Almost done

Install the entrance ladder

It is important that you can enter and exit your Multi-Pond safely. This is why we include a stainless steel ladder that you will have to assemble according to the enclosed installation instructions. After reading the instructions, use the included flange to attach the ladder to the specified spot on the wooden boardwalk. Especially for this purpose, an additional piece of square-shaped timber ($31\frac{1}{2}$ " x $6\frac{1}{4}$ " x $7\frac{3}{4}$ " or 80 x 16 x 20 cm) is included, which you can install to reinforce the appropriate place on the boardwalk. Simply anchor the ladder parts to the boardwalk and hang the ladder.

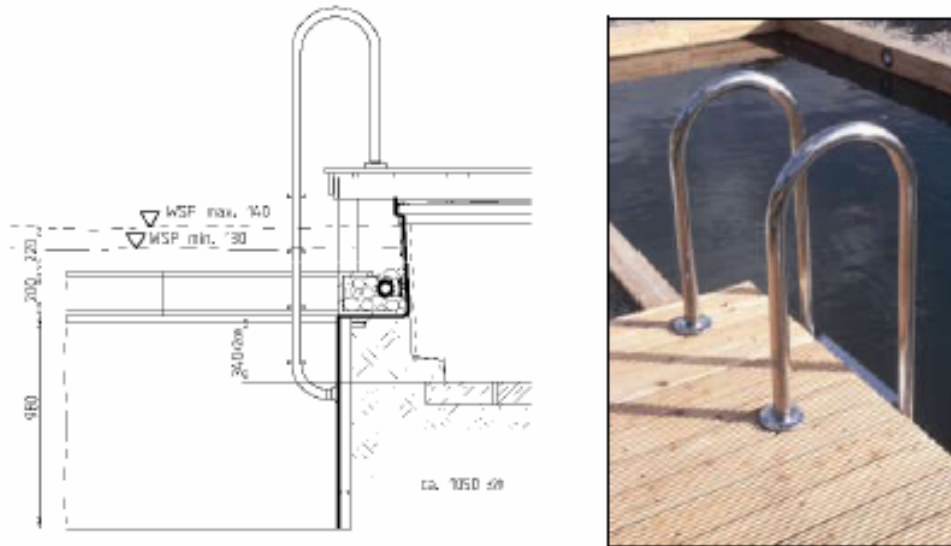

Fig.: Entrance ladder

Shaping the peripheral area

The peripheral areas of our Multi-Pond Set, which, in the meantime, you have planted and filled with gravel, can now also be designed according to your personal taste. A nice way of doing this is to use large natural stones. They are perfectly suited for stepping and jumping stones and can be integrated very smoothly. They offer an abundance of different design possibilities and help you create your very own unique Multi-Pond.

Initial operation of your pond system

You are now ready to put your pond system into operation. However, before operating your filter unit, perform a final check of the entire system.

- Your pond should be filled all the way to the maximum edge of the overflow barrier!
- Check the connection at the filter outlet
- Start operating the pump

The filter system will now communicate with your Multi-Pond. The water levels inside the filter system and in the pond will find a common balance.

Within a few seconds, the pump will slightly lower the water level inside the filter system.

From now on, you should keep the water cycle running 24/7 365 days a year.

Both the filter system and the regeneration zones work on a biological basis. As nitrificants (micro-organisms) will settle in to process any present nutrients for their own consumption, they will also reduce/eliminate these nutrients. The living conditions of these organisms call for a constant supply of oxygen. This is why you will have to operate your system continuously.

Winter operation

During the winter months (temperatures below 46°F, 8°C), micro-organisms will slow down their biological activity. Therefore, you could, in theory, turn off your filter system. However, we recommend that you keep the system running even throughout this season. For instance, the filter system is capable of filtering pollutants such as leaves mechanically. It can, therefore, help avoid an increase in water pollution before spring. The continuous operation of your system will, for the most part, also prevent your pond from freezing over.

The system's low operating costs of no more than 45.00/year along with the overall benefits for your entire system should also help you decide in favor of continuous operation.

Maintaining your system

The basics

Please note that the performance of a bio-mechanical processing system has its limits, as any excess addition of nutrients may temporarily affect the condition of your biotope or even shorten its lifespan.

We would, therefore, like to ask you to follow these fundamental rules:

- (1) Protect your Multi-Pond against any extraordinary nutrient sources such as nutrient-rich filler water, surface water flooded in from fertilized fields, re-filling the water with dirty rainwater collected from rooftops.
- (2) Relieve your pond by taking appropriate care measures.
- (3) Avoid applying or adding any toxic or anti-bacterial substances at all costs!
- (4) Do not release fish into your Multi-Pond.

Thanks to the interaction of its technical and substrate components, a processing system can offer you the following advantages:

- Removal of surface pollution thanks to the skimmer installed in your filter
- Biomechanical water filtration
- Permanent flow through the regeneration zone

In the spring, before the pond reaches its biological level of activity, you may experience a short-term increase in algae formation.

Another wide-spread phenomenon is blooming algae caused by reduced biological activity in the summer time. However, this kind of algae formation will not affect the functionality of your Multi-Pond. To help you reduce your maintenance efforts during these times of the year, Oase offers you water care products capable of reducing the formation of algae. Contact us for more product information.

What tools do you need to take care of your pond?

Use the following equipment to take proper care of your pond:

- Telescopic rod
- Pond net (e.g. Oase pond net)

- Broom
- Pond waders
- Rose clippers
- Pond mud vacuum (Pondovac 3)

What will you have to do on a regular basis and how often?

Despite a constant surface flow, the deep zone area of every Multi-Pond Set will collect some sediments (light brown sediment flakes). These sediments are stirred up during use and cause the water to become murky for a brief period of time.

Thus, to maintain the attractive visual appearance of your natural Multi-Pond set, you should clean the pond liner of your Multi-Pond area using a mud vacuum (Pondovac 3).

By regularly cleaning the floor of your pool, you will deprive your pond of nutrients bound in the sediments and, thereby, prevent it from silting.

We recommend that you vacuum your pond floor every 3 weeks. In addition to vacuuming the deep zone area and filtering out any dead plant material, you should also perform some seasonal cleaning in the spring, the summer, and the winter (no more than 2 – 3 times a year).

When performing this kind of maintenance, you should check on the plants in the shallow area of your pond. Vigorously sprawling plants may push aside other species in your pond. In the event of excessive sprawling, you may have to reduce or re-plant your plants.

In the fall, before the leaves start to fall, you should cut back your water plants at about 10 cm above the water surface. In addition, spread a net across your pond to prevent leaves from falling onto the water surface.

Instead, you can also regularly filter out the leaves using a pond net.

The filter system

Your Multi-Pond Set filter system works both mechanically and biologically.

Cleaning by biological filters

The biological component of your filter system does not require any special maintenance. The longer the system operates, the more the micro-organic population inside the filter will flourish. This is why you should only clean the biological filter media in case they have become completely blocked. You will be able to tell that this has happened when the water level inside the filter has started to rise due to the counter pressure exercised by the blocked filter media. However, this is not to be expected, as the filter system is designed to withstand the typical wear of a Multi-Pond. Moreover, the biological decomposition processes taking place inside the filter prevent the filter media from becoming blocked.

Should the filter sponges have collected too much dirt, simply remove any coarse dirt to prevent the filter biology from becoming destroyed. Therefore, avoid removing the filter media from the system to clean them painstakingly.

Read the instructions included with your filter system before cleaning your filter media.

The development of the filter biology

By creating the ideal living conditions for the organisms living in your pond, you will automatically ensure that the population of micro-organisms will reach the desired levels. However, you can promote and accelerate the development of your pond biology by "vaccinating" your pond with filter bacteria.